

Agricultural Microbiology

PRACTICAL MANUAL

Course No. ABB 156 2(1+1)

For Undergraduate Agricultural Students



Dr. Umesh Pankaj

2020

**College of Horticulture & Forestry
Rani Lakshmi Bai Central Agricultural University
Jhansi-284003**

Syllabus:

Practical: Examination of natural infusion and living bacteria; examination of stained cells by simple staining and Gram staining. Methods for sterilization and nutrient agar preparation. Broth culture, agar slopes, streak plates and pour plats, turbid metric estimation of microbial growth, mushroom culture- Spawn production, Culture and production techniques, harvesting, packing and storage.

Name of Student

Roll No.

Batch

Session

Semester

Course Name :

Course No. :

Credit

Published: 2020

No. of copies:

Price: Rs.

CERTIFICATE

This is to certify that Shri./Km.ID No.....has completed the practical of course.....course No. as per the syllabus of B.Sc. (Hons.) Agriculture/ Horticulture/ Forestry semester in the year.....in the respective lab/field of College.

Date:

Course Teacher









INDEX

S. No.	Content	Page nos.
1.	To know about basic requirements of a microbiology laboratory	
2.	To know about important instruments used in Microbiology Laboratory	
3.	To study application of sterilization methods	
4.	To prepare culture medium	
5.	To isolate the bacterial, fungal and actinomycetes population from soil	
6.	To know the cultural characteristics of microorganisms	
7.	Isolation of pure culture from a spread plate or mixed population	
8.	To perform the motility test of Microorganisms	
9.	To know the preservation of Microorganisms	
10.	To identify fungi on the basis of morphological and microscopic appearance	
11.	To perform simple staining	
12.	To perform negative staining	
13.	To perform Gram's staining	
14.	To estimate microbial growth through Turbid metric	
15.	To isolate plant growth promoting rhizobia (PGPR) from root nodule	
16.	To isolate PGPR free living nitrogen fixer Azotobater from soil	
17.	To isolate PGPR phosphate solubilizing bacteria (PSB) from soil sample	
18.	To isolate high cellulose degrading bacteria from soil sample	
	Appendices	

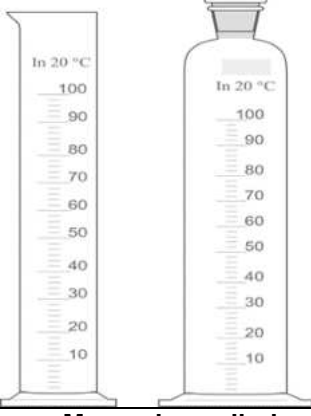
Practical No. 1

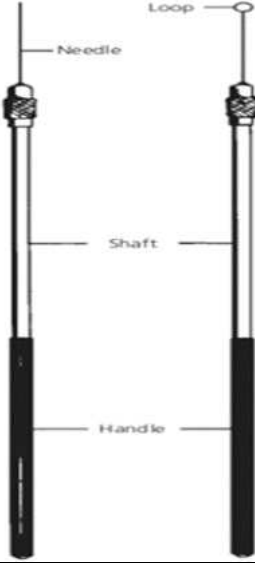
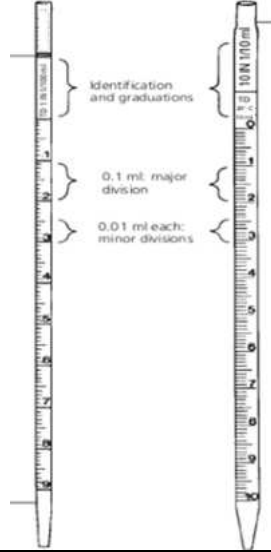
Objective: To know about basic requirements of a microbiology laboratory

A microbiology laboratory requires well-built rooms equipped with common glassware, tools and equipment. Some of the most important glassware and tools used are following:

		
Petri dish	Screw-capped glass bottle	Measuring cylinder
		
Glass spreader	Inoculating loop and needle	Pipettes
		
Bunsen burner	Culture Tube	Test Tube

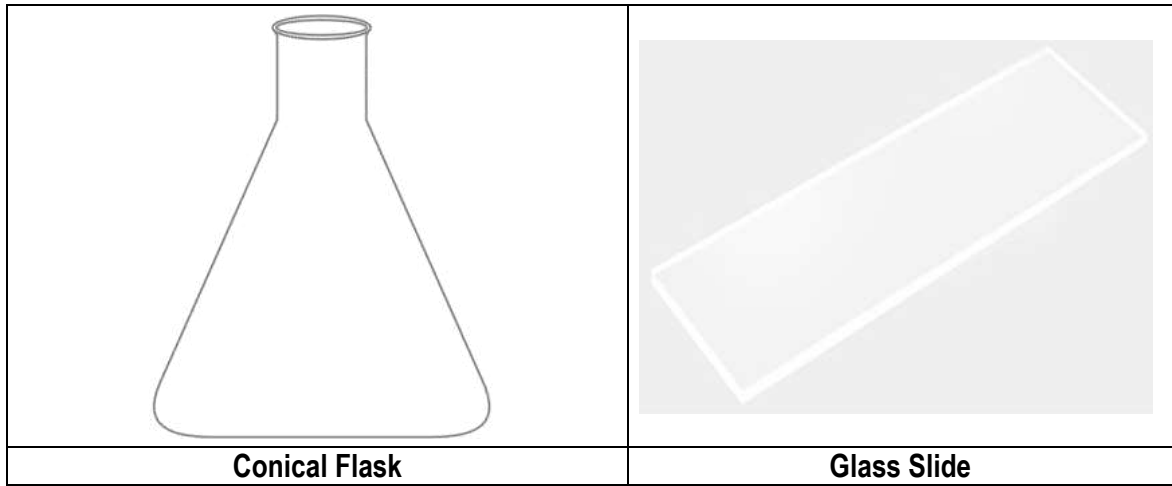

Problem: Draw the tools and glassware as per the instruction given by course instructor and write its use:

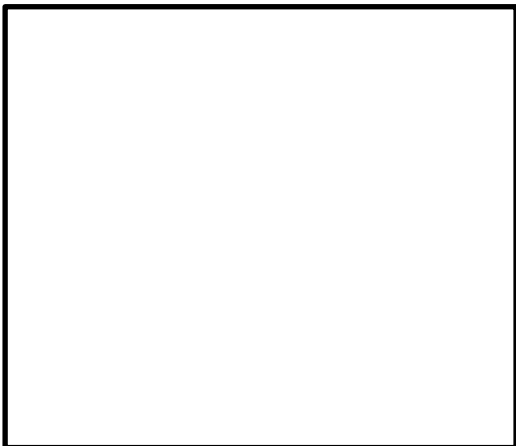

.....
.....
.....
.....
.....
.....

Practical No. 2

Objective: To know about important instruments used in Microbiology Laboratory

Microbiology laboratory should be equipped with some of major instruments like Microscope, Autoclave, Laminar air flow, Incubator, Hot Air Oven, Deep Freezer, Weighing balance, pH meter etc.

Compound Light Microscope

It is an instrument based on magnifying the images using different combination of objective and ocular lens.

Parts of Microscope:

- a. **Eye piece (Ocular lens):** The eyepiece adds magnification can be
- b. **Coarse adjustment knob:** The coarse adjustment is used to bring the objective down into position over any object on the stage.
- c. **Fine adjustment knob:** Used to focus on the specimen.
- d. **Objective lens:** Rotating the objective nosepiece allows different magnifications e.g. 10x, 20x, 40x and 100x, to be selected. The objective provides a magnified and inverted image.
- e. **Stage:** The stage has a hole in the center that permits light from below to pass upward into the lenses above. The object to be viewed is positioned on the stage over this opening.
- f. **The condenser:** Focuses light onto the specimen to give optimum illumination.
- g. **Illuminator:** Illuminator fit at the base is the source of light. Light is directed upward through the abbe condenser.

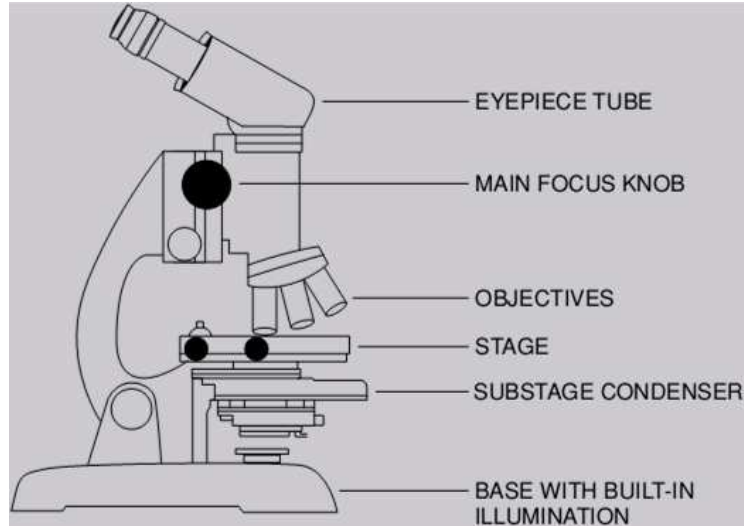

Problem: Draw the picture of light microscope and labelled it properly:



Precautions and safety measures:

.....

.....

.....

.....

.....

.....

Autoclave

Principle: It is based on the moist heat sterilization, where pressure (15 psi) at high temperature (121°C) for definite period of time (30 minutes) is used for killing for microorganism in samples which are not destroyed through heat.

Application:

.....

.....

.....

.....

.....



Operating Procedure:

Step 1.

.....

Step 2.

.....

Step 3.

.....

Step 4.

.....

Step 5.

.....

Step 6.

.....

Problem: Draw the picture of autoclave and labelled it:

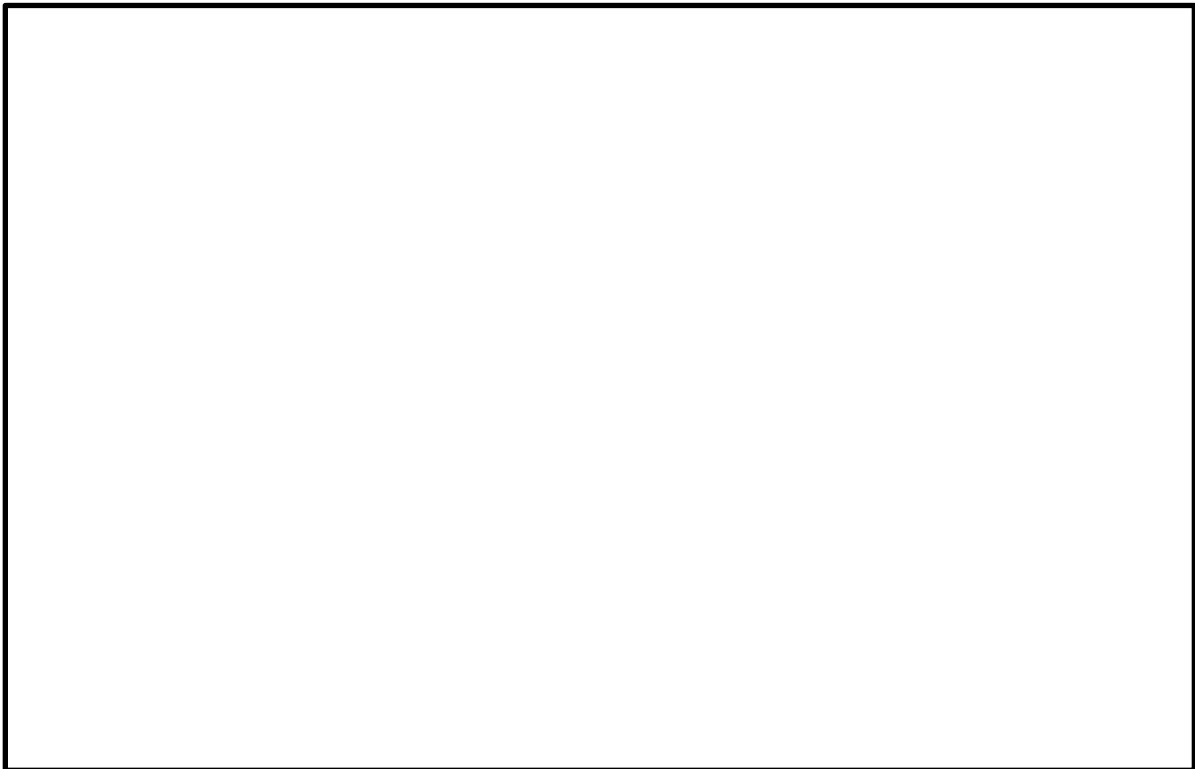

Precautions and safety measures:

.....

.....

.....

Laminar air flow/safety cabinets or Aseptic hood

Principle: Laminar flow is mere an indication of the direction of movement of air entering a closed compartment meant for aseptic processing of formulations or at working desk to avoid contamination. The air supplied is via “High-Efficiency Particulate Air” (HEPA) filters. These are filters with pore size of 0.45μ and having an air velocity of ~ 99 km/s. Laminar air can be supplied in the desired area horizontally, vertically, or curvilinearly. It has a UV lamp used for sterilization of working desk. The killing of microorganisms by UV light in a closed wooden/steel chamber.

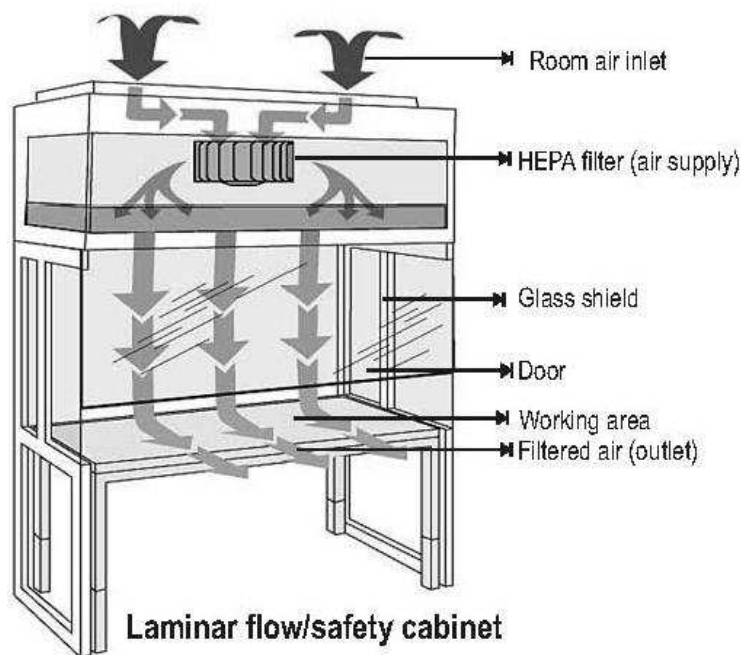

Laminar flow/safety cabinet

Application:

.....
.....

Operating Procedure:

Step 1.

.....
.....

Step 2.

.....
.....

Step 3.

.....
.....

Step 4.

.....
.....

Step 5.

.....
.....

Problem: Draw the picture of autoclave and labelled it:

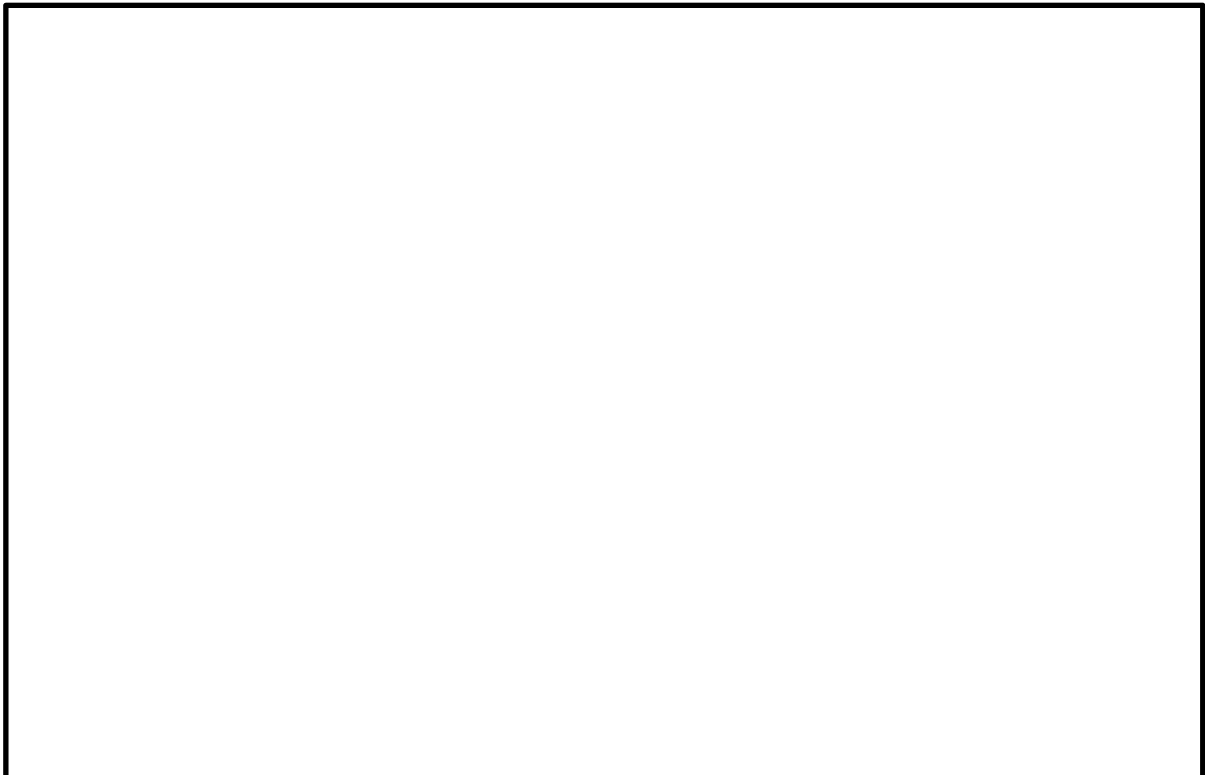

Precautions and safety measures:

.....
.....
.....
.....

Incubator

Principle: It is instrument that used for micro-organisms growth under controlled and systemic manner at optimum or constant temperatures.

Application:

.....

.....

.....

.....

Operating Procedure:

Step 1.

.....

Step 2.

.....

Step 3.

.....

Step 4.

.....

Step 5.

.....

Problem: Draw the picture of autoclave and labelled it:



Precautions and safety measures:

.....

.....

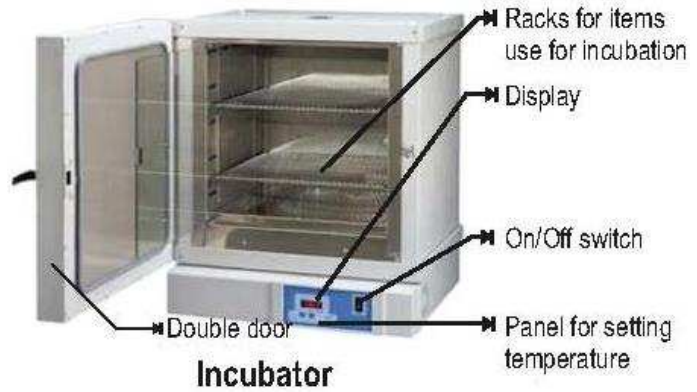

Hot Air Oven

Principle: It involves sterilization by dry heat. The instrument is composed of double-walled chamber of stainless steel or aluminium separated from the outer insulated layer through glass wool filling. Heating is achieved by electric coils filleted inside the double wall.

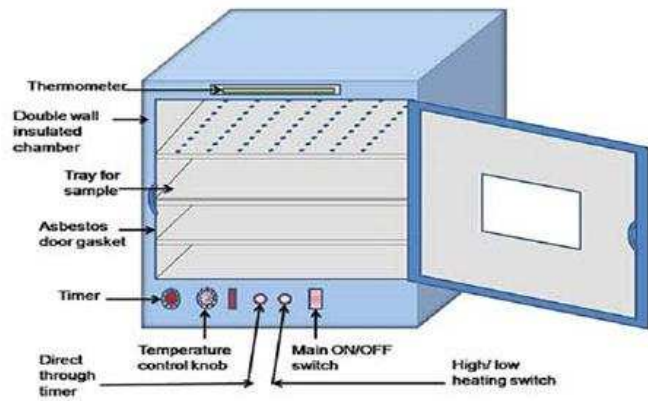

Hot air oven

Application:

.....

.....

.....

Operating Procedure:

Step 1.

.....

Step 2.

.....

Step 3.

.....

Step 4.

.....

Step 5.

.....

Problem: Draw the picture of autoclave and labelled it:



Precautions and safety measures:

.....

.....

Practical No. 3

Objective: To study application of sterilization methods

Principle: Sterilization is the process of destroying or physically removing all forms of microbial life including vegetative cells, spores and viruses from a surface, a medium or an article. The principal reasons for controlling microorganisms are:

- 1. To prevent transmission of disease and infection
- 2. To prevent contamination by undesirable microorganisms
- 3. To prevent deterioration and spoilage of materials by microorganisms

Methods: The methods of sterilization employed depend on the purpose for which sterilization is carried out, the material which has to be sterilized and the nature of the microorganisms that are to be removed or destroyed. The various agents used in sterilization can be grouped into physical and chemical agents.

A. Physical Methods

Sunlight:

.....

.....

Drying:

.....

Filtration:

.....

.....

Heat:

i. **Dry** **heat** **(Flaming,** **Incineration)**

.....

.....

ii. **Moist** **heat:**

.....

.....

B. Chemical method

Ethylene **oxide/** **Alcohol:**

.....

.....

Nitrogen dioxide:

.....

Ozone:

.....
Bleach:

.....
Glutaraldehyde and Formaldehyde:

.....
Hydrogen Peroxide:

.....
Peracetic Acid:

.....
Radiation sterilization (Ionizing radiation sterilization, Non-ionizing radiation sterilization):

.....
Problem: Which method is most suited for sterilization of glassware?

.....
Problem: Mention the sterilization method employed for media, oil, wax and antibiotic, plastic ware separately. Also write reason for using different methods.

.....
Problem: How sterilization is differs from sanitization, disinfection and pasteurization?

.....

.....

.....

.....

.....

.....

.....

.....

.....

.....

.....

Practical No. 4

Objective: To prepare culture medium

Principle: The general growth requirement of any microbial growth support medium is source of carbon, nitrogen, phosphorus, sulfur, trace elements, and water. Under laboratory condition the nutrient mixture on which micro-organisms grow is called culture medium, and microorganism is termed culture.

Materials: Petri plates, filter paper, Bunsen burner, 70% ethanol, sterilized cotton, Tween 80, inoculation loop, medium ingredient, culture tubes, laminar airflow, distilled water, glass screw cap tubes, vortex mixture, conical flask.

Procedure:

1. Take clean, dry 500 ml of conical flask; prepare cotton plug for mouth of flask; the plug should be tight enough to restrict passage of any microbial contaminant and loose enough to allow exchange of air and moisture inside the flask.
2. Calculate the composition of medium for 300 ml
3. Weigh media ingredients using weighing balance; firstly, tear the weight of paper on which weighing is done; the sequence of weighing should be from non-hygroscopic (non-sticky) ingredient first to hygroscopic ingredients.
4. While adding ingredient to flask, care should be taken to avoid sticking of medium components to walls. The water should be poured at last from walls of flask so as to dissolve any sticky medium ingredients.
5. Cover the mouth of flask with cotton plug and cover it with newspaper.
6. Autoclave media at 121°C, 15 lbs., 15 min. Now, place the sterilized Petri plate bundle and media in laminar airflow. Close the lid of laminar airflow. Switch on the UV light for 10–15 min. Allow the media to cool around 45 °C or flask becomes easy to hold in hand, the media can be poured.
7. Pour the media into the plates by open the plate at 45° angle facing toward flame inside the laminar airflow.
8. Keep the poured plates aside and allow the plates to solidify at room temperature.

Observation: Observe the poured media plate after 24 hours for absence of contamination.

Problem: Mention the types of media on basis of composition?

.....

.....

.....

.....

Practical No. 5

Objective: To isolate the bacterial, fungal and actinomycetes population from soil

Principle: Microorganisms are abundant and ubiquitous in our environment. They occur in air, soil, water, food, sewage decomposing matter, living plant, and on body surface. The microbiologist separates these mixed population into individual species for study. A culture containing a single unadulterated species of cells is called a **pure culture**. Several different techniques are applied to isolate and study microorganisms in pure culture. For isolation, several media (solutions containing all the nutrients required for the growth of micro-organisms) are employed.

The serial dilution agar plating methods or viable plate count method is one of the commonly used procedure for the isolation and enumeration of fungi, bacteria and actinomycetes which are the most prevalent microorganisms. This method is based upon the principle that when material containing microorganisms is cultured each viable micro-organism will develop into a colony, hence the number of the colonies appearing on the plate represent the number of living organisms present in the sample.

Materials: Soil sample, media plates
1. Nutrient agar (for bacteria), 2. Sabouraud's dextrose agar (for fungi), 3. Glycerol yeast agar (for actinomycetes), Chlorotetracycline, Streptomycin sulphate, 90ml sterile water blanks, sterile pipettes (10ml, 1ml), Spreader, Bunsen burner, glass marking pencil

Procedure:

1. Collect soil samples at random, minimum, from a field, mix thoroughly to make a composite sample for a microbiological analysis.
2. Label 90ml sterile water blanks as 1, 2, 3, 4, 5, 6, and 7 and sterile petri dishes as 10^{-2} , 10^{-3} , 10^{-4} , 10^{-5} , 10^{-6} , 10^{-7} with glass marking pencil.
3. For soil dilution and preparation of further serial dilution follow the method shown in Figure.
4. Transfer 1ml aliquots from different dilution into selected plates as follow:
 - i) For bacteria- Use 10^{-4} to 10^{-7} dilutions for spreading over Nutrient agar medium plate.
 - ii) For actinomycetes- Use 10^{-2} to 10^{-5} dilutions for spreading over Glycerol yeast agar medium plate.
 - iii) For fungi- Use 10^{-2} to 10^{-5} dilutions for spreading over Sabouraud's dextrose agar medium plate
5. Now, spread the aliquot evenly over surface of medium and incubate the plate at 25°C for 2-7 days.

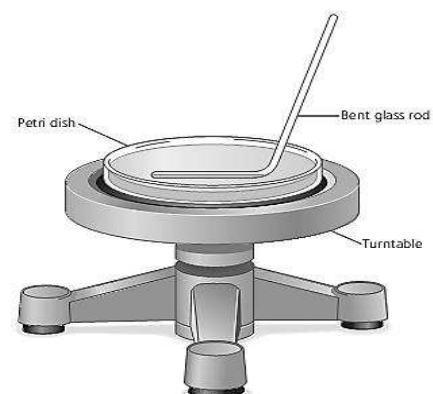
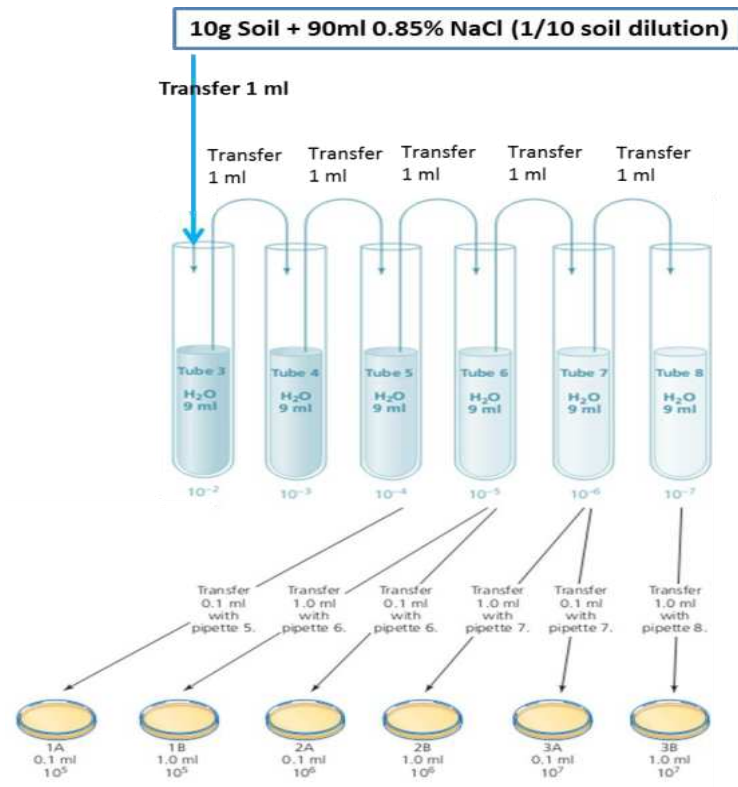

Observation: Observe the plate for number and distribution of colonies of bacteria, fungi and actinomycetes from each dilution.

Problem: Calculate the number of organisms per gram of the soil by applying the formula:

$$\text{Viable cells /g dry soil} = (\text{Mean plate count} \times \text{Dilution factor}) / (\text{Dry weight of soil})$$

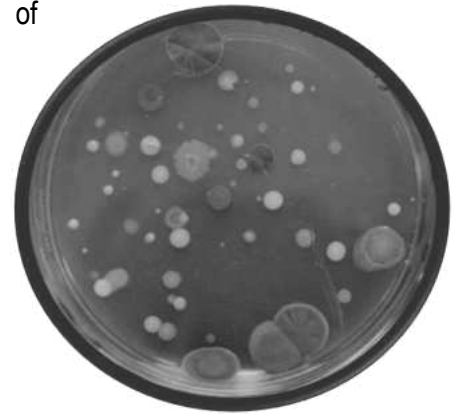

Plate showing mix population appeared from soil sample after incubation

Note the observation and results:

Sample/plates	Dilution factor	No. of colonies	Bacterial count (cfu)	Fungal Count (cfu)	Actinomycetes count (cfu)

.....

Problem: Describe the pour plate isolation methods

.....

Problem: Write the precautions taken during isolation of microorganisms:

.....

Objective: To know the cultural characteristics of microorganisms

Principle: When grown on a variety of media, microorganisms will exhibit differences in the macroscopic appearance of their growth. These differences, called cultural characteristics, are used as a basis for separating microorganisms into taxonomic groups. The cultural characteristics for all known microorganisms are contained in Bergey's Manual of Systematic Bacteriology. They are determined by culturing the organisms on nutrient agar slants and plates, in nutrient broth, and in nutrient gelatin. The patterns of growth to be considered in each of these media are described below, and some are illustrated in Figure.

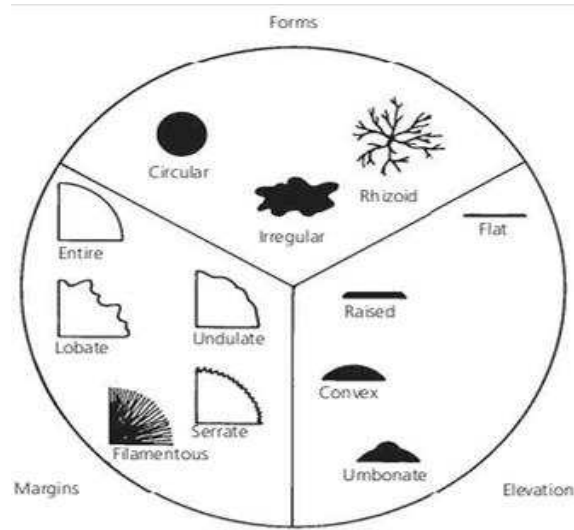

(b) Colonies on agar plates

Materials: Microorganisms growth plate, Light emission plate, marker

Observation and Results:

1. **Size:** Pinpoint, small, moderate, or large.
2. **Pigmentation:** Colour of colony.
3. **Form:** The shape of the colony is described as follows:
 - a. **Circular:** Unbroken, peripheral edge.
 - b. **Irregular:** Indented, peripheral edge.
 - c. **Rhizoid:** Root like, spreading growth.
4. **Margin:** The appearance of the outer edge of the colony is described as follows:
 - a. **Entire:** Sharply defined, even.
 - b. **Lobate:** Marked indentations.
 - c. **Undulate:** Wavy indentations.
 - d. **Serrate:** Tooth like appearance.
 - e. **Filamentous:** Threadlike, spreading edge.
5. **Elevation:** The degree to which colony growth is raised on the agar surface is described as follows:
 - a. **Flat:** Elevation not discernible.
 - b. **Raised:** Slightly elevated.
 - c. **Convex:** Dome-shaped elevation.
 - d. **Umboate:** Raised, with elevated convex central region.

Problem: Note the observation and results:

Culture plates	Culture characteristic
Plate-1	
Plate-2	
Plate-3	

Problem: Mention the morphological differences among bacteria, fungi and actinomycetes:

.....

.....

.....
Problem: Precaution taken during picking the colonies and streaking the culture:

.....
.....
.....
.....
.....
.....
.....
.....
.....
.....
.....

Problem: Draw the streaked plate by the student:

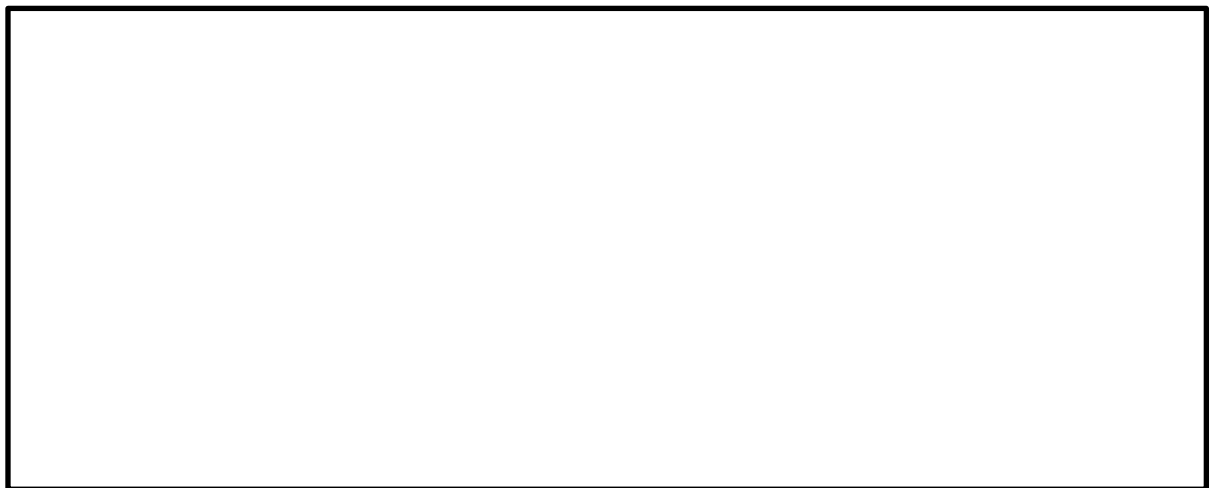

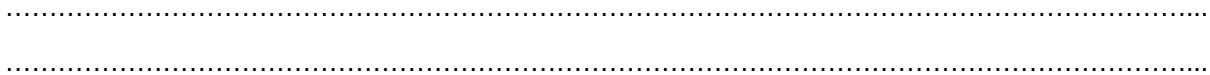

Practical No. 8

Objective: To perform the motility test of Microorganisms

Principle: The motility test is often used to distinguish certain bacteria. The motility determines the presence of flagella, external appendages used by bacteria for movement. Bacteria with flagella, such as *Proteus mirabilis*, are called motile, while bacteria without flagella, such as *Staphylococcus epidermidis*, are called nonmotile.

Materials: The semisolid (0.5% agar) SIM (Sulfide, Indole, Motility) medium, Test tube, Inoculating needle, Bunsen burner, Incubator, Glass marker

Procedure:

1. Prepare semisolid SIM medium poured into test tube (half fill) and autoclave at 121°C, 15 min for 30 minutes. Cool the medium.
2. Label tube as one for culture and one for blank.
3. Now, sterilize the needle, obtain a small bit of culture and inoculate the medium by inserting straight down the needle up to bottom and back out.
4. Incubate the inoculated tube at 30 °C for 48 hours.
6. Examine tube for growth pattern.

Observation: Observe the tube for growth around the inserted needle mark, growth is seen macroscopically as turbidity extending through the semisolid medium.

Result: Find the culture is showing motility or not.

Problem: Draw the observation taken in term of motility showing in tubes:

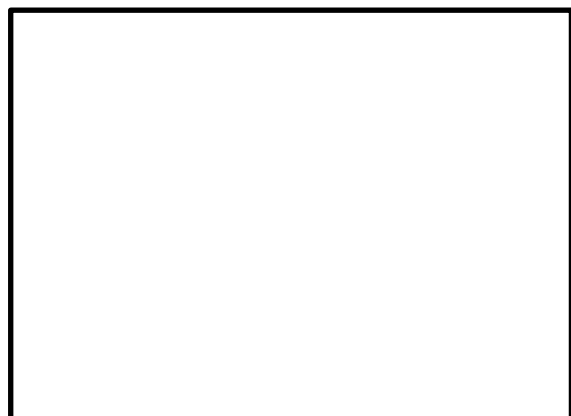

Problem: What do you understand by importance of motility, spot some activity in environment :

.....

.....

.....

.....

Precaution taken during the experiment:

.....

.....

.....

Practical No. 9

Objective: To know the preservation of Microorganisms

Principle: Microorganisms are continuously used for production of antibiotics, enzymes, vitamins, etc., biotransformation of biomolecules, bioremediation, bioconversion, bioprocessing of goods, etc. Thus, proper maintenance and preservation of microbial cells possessing desired potential (importance) is required to ensure long-term availability of them without loss in their metabolic potentials. The basic principle behind preservation of microbial cultures is to reduce their metabolism without disturbing cell integrity. However, the choice of method to be used depends on type of microorganism, purpose of storage, and duration of preservation.

Materials: Culture tubes, cotton plugs, Bunsen burner, cotton, ethanol (70% v/v), Media (as per culture requirement), autoclave, inoculation loop, inoculation needle, refrigerator, glass funnel, conical flask, hot plate, weighing machine, blotting paper.

Procedure for slant preparation:

1. Weigh the medium ingredients in clean glass conical flask, and boil the medium ingredient for 10 min on hot plate.
2. When temperature of medium cools down to 50°C, pour it in culture tubes with the help of glass funnel fill approximately 1/3 of tube with medium.
4. Insert cotton plug in culture tubes, and make a bundle of seven tubes. Cover the bundle with paper, and autoclave the bundle of tubes in upright position at 121°C for 15 min at 15 lbs.
6. After autoclaving take out the bundle of tubes, and keep it in an 30° angle and allow the media in tubes to solidify.
8. Now, streak or point inoculate the slants with pure culture of microorganism inside the biosafety cabinet.
9. Incubate the tube at appropriate conditions as mentioned: Bacteria:-37°C for 24 h; Yeast:-28°C for 24-48 h; Fungi:-28°C for 2-4 days; Actinomycetes:- 28°C for 2-4 days.
10. The preservation is done in refrigerator at 5–10°C. The slant culture storage period in refrigerator is 2–3 months.
12. Thereafter sub-culturing should be done whenever required.

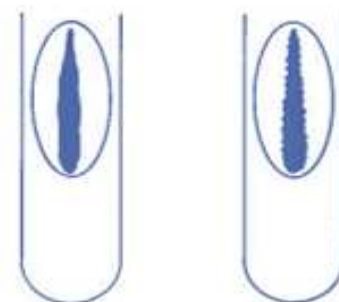

Inoculated Slant culture

Problem: Observe the viability of preserve culture after one week:

.....

.....

.....

.....

.....

.....

.....

.....

.....

.....

.....

.....

.....

.....

.....

.....

.....

.....

.....

.....

.....

.....

Problem: Mention the other preservation method for microorganism?

.....

.....

.....

.....

.....

.....

.....

.....

.....

.....

.....

.....

.....

.....

.....

.....

.....

.....

.....

.....

.....

.....

.....

Precaution for preserving the microorganisms:

.....

.....

.....

.....

.....

.....

.....

.....

.....

.....

.....

.....

.....

Practical No. 10

Objective: To identify fungi on the basis of morphological and microscopic appearance

Principle: Molds are the major fungal organisms that can be seen by the naked eye. We have all seen them growing on foods such as bread or citrus fruit as a cottony, fuzzy, black, green, or orange growth, or as a mushroom with a visible cap attached to a stalk, depending on the mold. Specialized hyphae are produced from the aerial mycelium and give rise to spores that are the reproductive elements of the mold. Molds can be identified as to spore type and shape, type of sporangia, and type of mycelium.

Material: 7- to 10-day old pure cultures plate of fungi grown on Sabouraud agar medium, Lactophenol cotton blue, Bunsen burner, Needle, glass coverslips, forceps, microscope, Marker pen and dropper.

Procedure:

1. Take a culture plate and note the colony characteristics such as pigmentation on front and revers of colony, texture of colony and ridges on the surface.
2. Place a drop of lactophenol cotton blue dye on clean glass slide.
3. Open the culture plate into laminar air flow and pick a small amount of culture with help of incinerated sterilized needle from one side of culture without disturbing the whole plate.
4. Mix the culture properly into the lactophenol cotton blue and place a coverslip over the culture spread.
5. Observe the culture slide under 10x, 20x and 40x for culture characteristics.

Observation: Microscopic observation such as hyphal growth (septate or non-septate), spore appearance, conidiophore appearance with help of Figure.

Result:

Problem: Write the fungal culture colony characteristics:

.....

Objective: To perform simple staining

Principle: Staining is a technique where specimens are stained with specific dyes to create contrast between the specimen and its background. Several different types of staining procedure are known today which are used to study morphological features of microorganism and their parts. Simple staining uses only one staining reagent and is used to determine shape, dimensions, and arrangement of microbial cells. Differential staining uses more than one staining reagent (dye) to differentiate cellular structures.

Material: Bacterial culture plate, methylene blue reagent, glass slide, inoculation loop, Bunsen burner, blotting paper, pipette, staining tray, binocular microscope.

Procedure:

1. Take 1–2 drops of sterilized water on clean glass slide.
2. Pick culture of bacteria with the help of inoculation loop under aseptic conditions, and make water suspension.
3. Prepare smear of bacteria by spreading it over slide.
4. Air-dry the smear and heat fix.
5. Spread 2–4 drops of staining reagent over the smear for 2–5 min.
6. Pour off the extra stain and wash the slide in running water.
7. Keep the slide in inclined position, and remove water droplets carefully using blotting paper.
8. View the slide under low (10x), high (40x), and oil immersion (100x) magnification of compound microscope.



Cocci



Rod

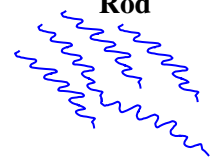

Spirilla



Comma

Observation: Observe the blue-coloured bacterial cell for their shape (cocci, rod, spiral, comma etc.) and arrangement (chain, clubbed or single) are visible under oil immersion microscope. Draw the diagram of it, and note down the observations.

Results:

Problem: Draw a bacterial cell shape and arrangement of given culture:

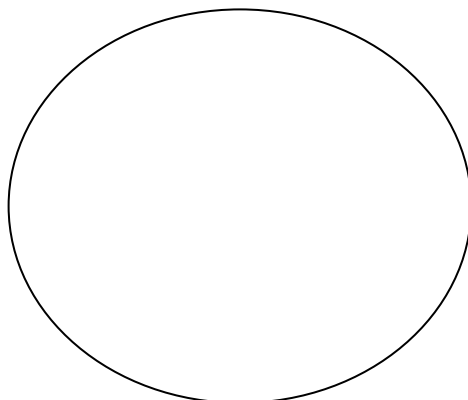

Field view-1

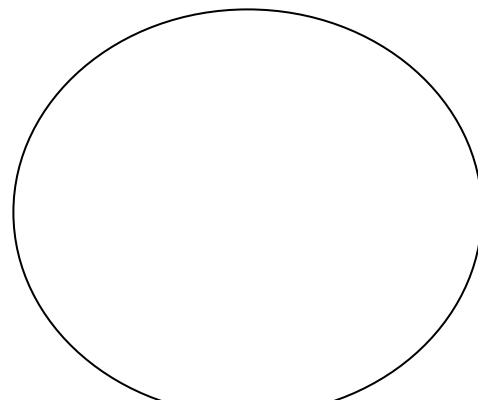

Field view-2

Precaution taken during simple staining:

.....

.....

Practical No. 12

Objective: To perform negative staining

Principle: The background of specimen (bacteria) gets stained instead of bacteria in negative staining; therefore, contrast is created. The acidic stains such as nigrosine and Indian ink are used. It relies on the principle that bacterial cell walls possess negative charge and thus repel acidic dye and do not get stained. The biggest benefit of this stain is that cell morphology remains intact and even capsulated bacteria can be observed.

Material: Bacterial culture plate, nigrosine stain, glass slide, inoculation loop, Bunsen burner, blotting paper, pasture pipette, staining tray, binocular microscope.

Procedure:

1. Prepare suspension of bacteria in sterile water blank using inoculation loop, under aseptic condition.
2. With the help of pipette, put 1–2 drops of bacterial suspension in clean glass slide, add 1 drop of nigrosine stain, and mix well with the help of loop.
3. Spread the suspension with the help of second slide. Stretch the slides from one end to another.
4. Dry the slide.

Observation: Examine slides under oil immersion microscope. Cells appear transparent against blue background. Draw the diagram of it, and note down the observations.

Results:

Problem: Draw a bacterial cell shape and arrangement of given culture:

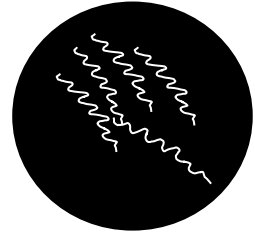
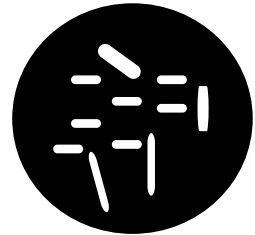
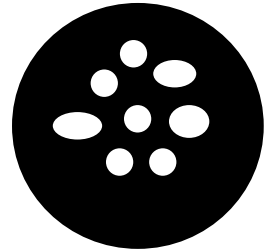

Bacterial cell visible with negative stain (colourless cell in dark background)

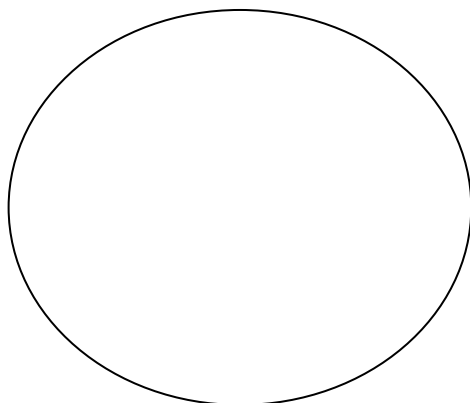

Field view-1

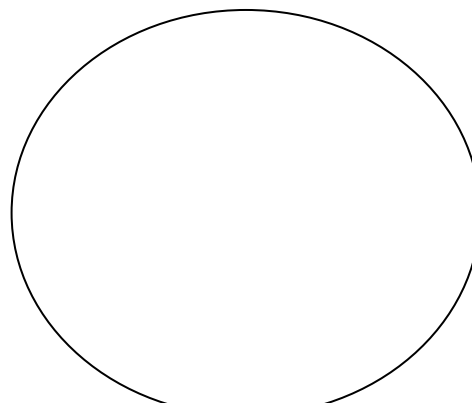

Field view-2

Precaution taken during negative staining:

.....
.....

Practical No. 13

Objective: To perform Gram's staining

Principle: The most important differential stain used in bacteriology is the Gram stain, named after Dr. Hans Christian Gram. It divides bacterial cells into two major groups, gram-positive and gram-negative based on their cell wall chemical composition, which makes it an essential tool for classification and differentiation of microorganisms. Differential staining requires the four chemical reagents that are applied sequentially after heat-fixed smear. The first reagent is called **primary stain** function to color all cells. The second stain is a **mordant** used to intensify the color of the primary stain. In order to establish a color contrast, the third reagent used is the **decolorizing agent**. The final reagent, the **counterstain**, has a contrasting color to that of the primary stain. In this way, cell types or their structures can be distinguished from each other on the basis of the stain that is retained (pink or purple).

Material: 24 hours old bacterial culture plate, Glass slides, Dropper, Crystal violet, Gram's iodine, 95% ethyl alcohol, and safranin.

Procedure:

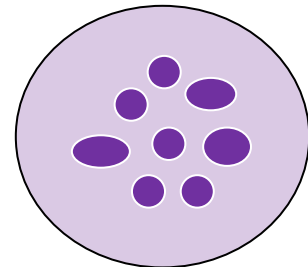
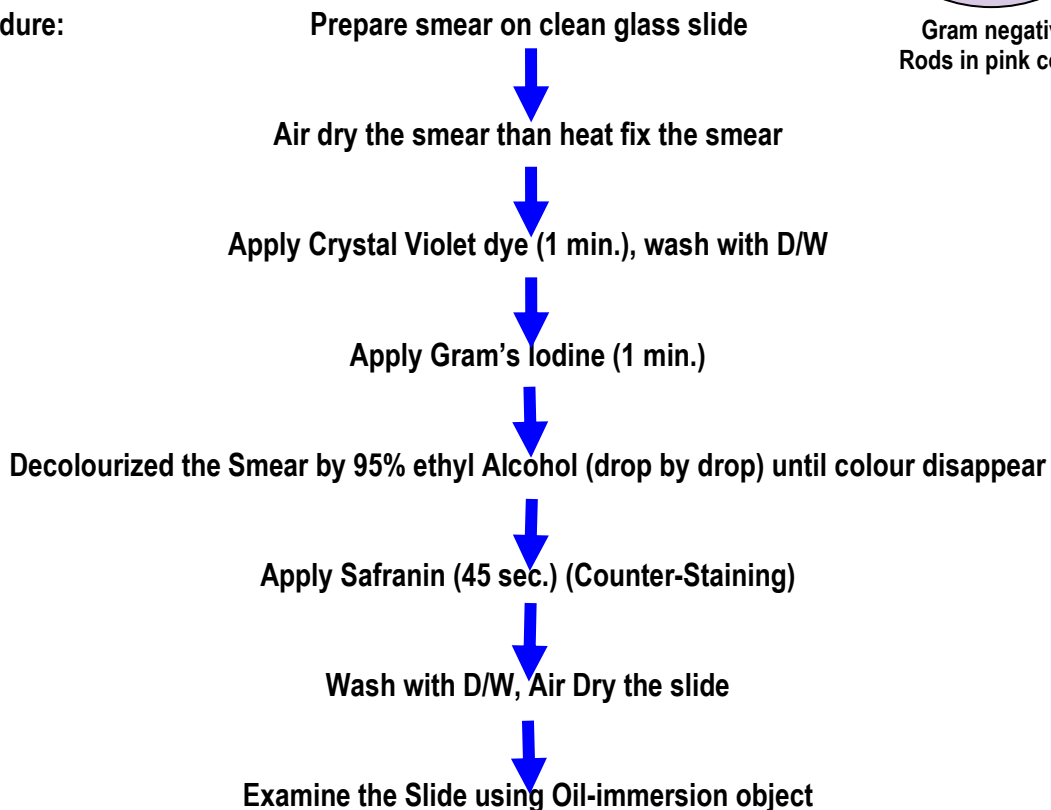

Gram positive:
Cocci in violet colour

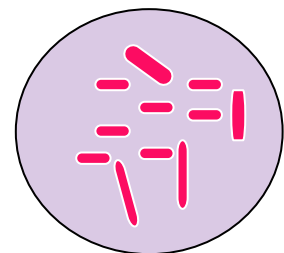

Gram negative:
Rods in pink colour

Observation: Pink-colored, rod-shaped cells are gram-negative rod, and those appearing violet (purple) cocci in clumps are gram-positive as viewed under oil immersion microscope (100x).

Practical No. 14

Objective: To estimate microbial growth through Turbid metric

Principle: Bacterial growth is measured in term of doubling of the cells and quantifies by turbidity in broth medium on incubation. Turbidity measurement is required spectrophotometer and its functioning based on Beer-Lambert law. It state that the transmission beam of light (T) at a single wavelength (mono-chromatic light) through a liquid culture. The cells suspended in the culture interrupt the passage of light, and the amount of light energy transmitted through the suspension is measured on a photoelectric cell and converted into electrical energy. The electrical energy is then recorded on a galvanometer as 0% to 100% T. A schematic representation of a spectrophotometer is shown in given below **Figure**. In practice, the density of a cell suspension is expressed as absorbance (A) rather than percent T, since A is directly proportional to the concentration of cells, whereas percent T is inversely proportional to the concentration of suspended cells. Therefore, as the turbidity of a culture increases, the A increases and percent T decreases, indicating growth of the cell population in the culture.

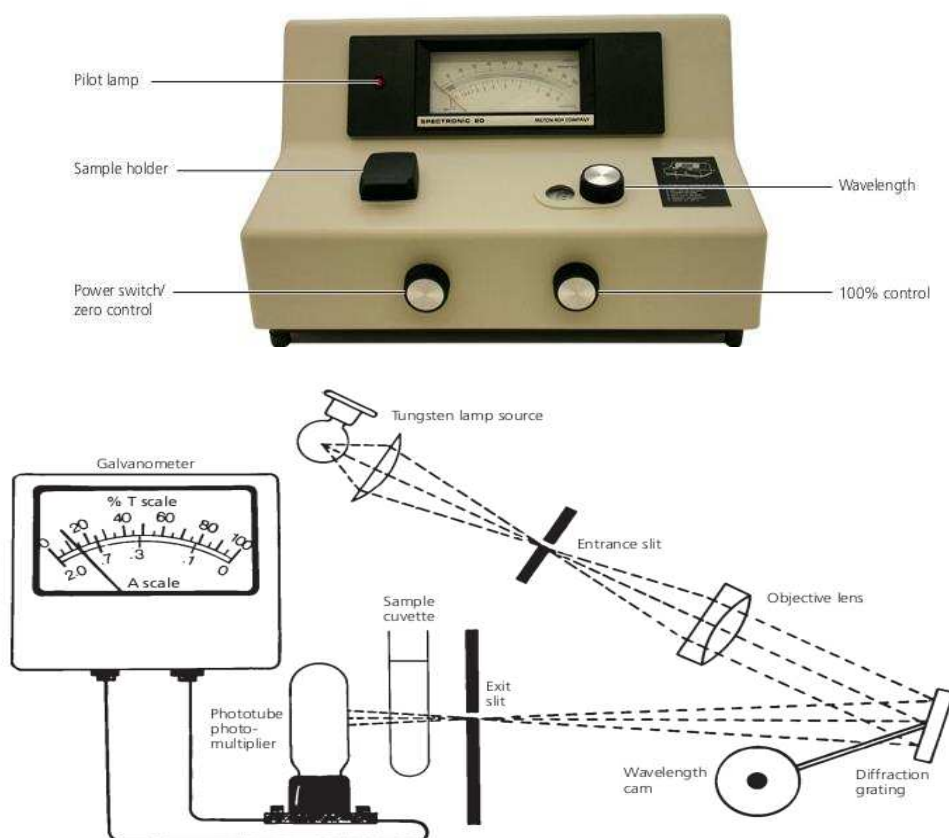

Schematic diagram of spectrophotometer and its functioning.

Materials: 12-hours old *E. coli* broth cultures suspension, Saline suspension, Trypticase soy broth (TSB), Bunsen burner, sterile 1-ml pipettes, glassware marking pencil, test tube rack, and Spectrophotometer.

Procedure: (1st step) for initial preparation

1. Prepare TSB medium and autoclave at 121°C, 15psi for 30 minutes and allow cooling. Now, using a sterile 1-ml pipette, add 0.1 ml of the *E. coli* culture 12 hrs old to sterile TSB medium flask.
2. Incubate the flask at shaker incubator for 6 hours at 37 °C and 120rpm.

2nd step for turbidity measurement: After finish the incubation period, follow the instructions below and refer to Figure for the use of the spectrophotometer to obtain the absorbance readings of inoculated cultures.

1. Turn the instrument on 10 to 15 minutes prior to use.
2. Set wavelength at 600 nm.
3. Set percent transmittance to 0% (A to 2) by turning the knob on the left.
4. Read the four TSB cultures as follows:
 - a. Wipe clean the provided test tube of sterile TSB broth that will serve as the blank for the TSB broth culture readings.
 - b. Insert the STB broth blank into the tube holder, close the cover, and set the A to 0 (percent T = 100) by turning the knob on the right.
 - c. Shake lightly or tap one of the tubes of TSB culture to resuspend the bacteria, wipe the test tube clean, and allow it to sit for several seconds for the equilibration of the bacterial suspension.
 - d. Remove the TSB broth blank from the tube holder.
 - e. Insert a TSB broth culture into the tube holder, close the cover, and read and record the optical density reading on note book.
 - f. Remove the TSB culture from the tube holder.
 - g. Reset the spectrophotometer to an A of 2 with the tube holder empty and to an A of 0 with the TSB blank.
 - h. Repeat Steps (c) through (g) to read and record the absorbance (O.D.) of the remaining TSB broth cultures at different time interval e.g. 30 min., 60 min., 90 min., 120 min., 150 min., 180 min. 210 min., and 360 min. to draw a growth curve and note the absorbance.

Observation and results: Record the optical density (O.D) of the sample on your note book. Plot a graph between O.D versus incubation time to prepare the growth curve and calculate the generation time for *E. coli* culture.

Problem: Take the observation at different time period given as following:

Sample	OD at 30 min.	OD at 60 min.	OD at 90 min.	OD at 120 min.	OD at 150 min.	OD at 180 min.	OD at 210 min.	OD at 360 min.
<i>E. coli</i>								
Unknown bacterial culture-1								
Unknown bacterial culture-2								

Problem: Draw a growth curve for test organism:

.....

.....

Practical No. 15

Objective: To isolate plant growth promoting rhizobia (PGPR) from root nodule

Principle: First bacteria was isolated from the root nodule by the Beijernick in 1888 and named *Bacillus radicola*, now it placed under the genus Rhizobium. They infect and live in symbiotic association with only the leguminous plant forming nodule in them and fix atmospheric nitrogen. Rhizobia are Gram-negative rods. Rhizobia are isolated from the root nodules by serial dilutions prepared from the root nodules or the fluid from crushed nodules is spread on the surface Yeast extract mannitol agar (YEMA) plates. Rhizobia luxuriously grow under at the temperature 26-27°C for 10 days.

Material: Root nodule, Yeast extract mannitol agar medium, 0.1% HgCl₂ or 3-5 % H₂O₂, 70% ethyl alcohol, sterile water blank (90ml, 10ml), Pipettes, Magnetic shaker, inoculating loop, Bunsen burner.

Procedure:

1. Prepare YEMA medium plates (see composition form Appendix 1)
2. Wash the root nodules in running tap water to remove adhering soil particles.
3. Immerse the nodules in 0.1 HgCl₂ or 3-5% H₂O₂ for 5 minutes to surface sterilizes these. Repeatedly wash the nodule in sterilized water for 3-4 times to get rid of the sterilizing agents.
4. Place the nodules in 70% ethyl alcohol for 3 minutes (if treated with HgCl₂). Repeatedly wash the nodule in sterilized water.
5. Crush a nodule in 1ml of water with sterile glass rod and make a uniform suspension of rhizobia with water.
6. Make serial dilution of nodule extract as the procedure described in **Practical- 5**.
7. Spread 1ml, each of suspension from various dilutions, on YEMA plates and incubate the plate at 26°C for 10 days

Observation: Observe the plates after 3-4 days incubation and regularly afterward for the development of rhizobia colonies.

Results: Large gummy colonies of rhizobia will appear on YEMA plates

Problem: Write the culture characteristics of appeared colony on YEMA plate

.....

.....

.....

.....

.....

.....

.....

.....

.....

.....

.....

.....

.....

.....

.....

.....

.....

.....

.....

.....

.....

.....

.....

Problem: To confirm rhizobacteria, further transfer on fresh nitrogen free medium

Practical No. 17

Objective: To isolate PGPR phosphate solubilizing bacteria (PSB) from soil sample

Principal: Phosphate solubilizing bacteria (PSBs) are important categories of PGPRs which are used in the form of biofertilizers. Phosphorous is the major essential macronutrient for plant growth and development and hence is commonly added as fertilizer to optimize yield. "PSBs have been used to convert insoluble phosphate into soluble forms available for plant growth.

Materials: Rhizospheric fresh soil sample, Pikovskaya's agar media, Sterile water blank, Pipette, Magnetic shaker, Bunsen burner, Glass marker

Procedure:

1. Prepare Pikovskaya's agar medium plate (see composition from Appendix 1)
2. Collect fresh rhizospheric soil and 10g sieved (2mm) soil mix in 90 ml sterile water blank and shake it for 15 minutes on magnetic shaker.
3. Make serial dilution of diluted soil (mother suspension) as the procedure described in **Practical- 5**.
4. Spread 1ml, each of suspension from various dilutions, on Pikovskaya's agar medium plates and incubate the plate at 28°C for 7 days.

Observation: Observe the plates after 7 days incubation for clear (transparent) zone around the colonies on to the medium plates.

Results: The PSBs colonies with clear hollow zone appear.

Problem: Write the culture characteristics of appeared colony on Pikovskaya's agar medium plate and draw the picture :

.....
.....
.....
.....
.....
.....
.....
.....
.....
.....
.....

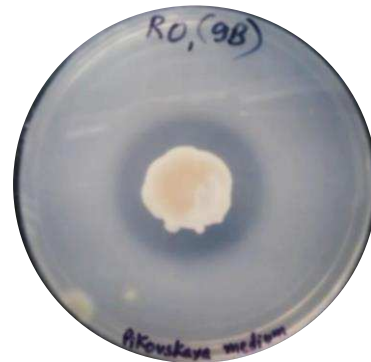

Plate showing phosphate solubilizing activity by bacterial colony

.....
.....
.....

Problem: Calculate the Phosphate Solubilisation Index (PSI) for quantitative analysis

.....
.....
.....
.....
.....
.....
.....
.....
.....
.....

Problem: How you calculate the phosphate solubilizing activity in broth medium

.....
.....
.....
.....
.....
.....
.....
.....
.....
.....
.....
.....
.....
.....
.....
.....
.....
.....
.....
.....
.....

What precaution should be taken during PSBs isolation:

.....
.....
.....
.....
.....

.....
.....
.....

Practical No. 18

Objective: To isolate high cellulose degrading bacteria from soil sample

Principal: Numerous microorganisms that are able to degrade cellulose have been isolated and identified. Cellulose is the most abundant biomass and most dominating agricultural waste on earth. It has a high potential for bioconversion to important bioproducts such as ethanol. The ability to obtain cheap ethanol will depend on the successful identification of novel cellulase producing strains. Microorganisms that can produce cellulase enzymes (cellulolytic microorganisms) can degrade cellulose.

Materials: Soil sample, carboxymethyl cellulose (CMC) agar media, Sterile water blank, Pipette, Magnetic shaker, Bunsen burner, Glass marker

Procedure:

1. Prepare CMC agar medium plate (see composition from Appendix 1)
2. Collect fresh soil sample and 10 g sieved (2 mm) soil mix in 90 ml sterile water blank and shake it for 15 minutes on magnetic shaker.
3. Make serial dilution of diluted soil (mother suspension) as the procedure described in **Practical- 5**.
4. Spread 1ml, each of suspension from various dilutions, on CMC agar medium plates and incubate the plate at 37°C for 3-5 days.
5. After incubation all the plates flooded with 1% (w/v) Congo-red solution for 15 min and discolored with 1 M NaCl for 15 min.

Observation: Observe the degradation zones visible (transparent) around the colonies, showing that the strains could hydrolyze CMC.

Results:

Problem: Write the culture characteristics of appeared colony on CMC agar medium plate and draw the picture of cellulolytic activity:

.....
.....
.....
.....
.....
.....
.....
.....
.....
.....

.....
.....
.....

Problem: Find the other sources for the isolation of cellulolytic microbes (bacteria and fungi)

.....
.....
.....
.....
.....
.....
.....
.....
.....

Problem: How you calculate the cellulase activity in broth medium

.....
.....
.....
.....
.....
.....
.....
.....
.....
.....
.....
.....
.....
.....
.....
.....
.....
.....
.....
.....
.....

What precaution should be taken during cellulolytic microbe isolation

.....
.....
.....
.....
.....

.....
.....
.....

Appendices

SAFETY RULES FOR MICROBIOLOGY LABORATORY

Read the following instructions carefully before beginning an exercise:

1. Eating or drinking in the laboratory is not permitted. Not even mouth pipetting.
2. Wash your hands with disinfectants when you arrive at the lab and again before you leave.
3. Wear laboratory coats in the lab. Students with long hair must put up the hair.
4. At the start and end of each laboratory session, students should clean their assigned bench-top area with a disinfectant solution provided. That space should then be kept neat, clean, and uncluttered throughout each laboratory period.
5. Label everything clearly. Sterilize equipment and materials.
6. Avoid loose fitting items of clothing. Wear appropriate shoes in the laboratory.
7. Reporting all spills and broken glassware to the instructor and receiving instructions for clean-up.
8. Turn off Bunsen burner when not in use.
9. Discard all cultures and used glassware into the container labelled CONTAMINATED. Plastic or other disposable items should be discarded separately from glassware in containers to be sterilized.
10. Before leaving the laboratory, see that all the equipment is in the proper location and gas and water turned off.
11. Cultures are not to be removed from the laboratory unless the instructor gives permission.
12. Treat all cultures as potentially pathogenic, i.e., flood areas with disinfectant if cultures are spilled, wash hands after contact and notify your instructor at once.

GUIDELINES FOR LAB NOTE BOOK

1. Keep the book neat and tidy.
2. Utilize the book efficiently preserving the legibility of your writing.
3. Name of the experiment should be entered along with the date of carrying out that experiment.
4. Aim/Objective: A clear objective should be mention. Next you mention the requirements for the experiment.
5. Summarize the theory and principle. This should be followed by the procedure.
6. Mention the general calculations for the experiment. It should contain all the related works of the project for which it is meant to.
7. Observations should be logically, Periodical or quantitative or qualitative including gel photographs, printouts, graphs, autoradiographs, etc.
8. Inference: The results obtained should be interpreted in accordance with the principle of the experiment.
9. Do not tear pages from the lab/field book. Number the pages of field book.
10. Do not over write if a mistake has been committed in recording, put a line over it and write the correct word again.
11. Complete the index, indicating the experiment, its serial number, page number on which it is written.
12. The notebook should always be up to date and may be collected by the lab in charge at any time.
13. You have to submit the field book and basic record at the end of every month on the date assigned.

PREPARATION OF MEDIA AND STAINS FOR EXPERIMENT

Normal Saline: 0.85 % (w/v) NaCl.

BACTERIAL GROWTH

Nutrient agar: Peptone 5.0 g, beef extract 3.0 g, NaCl 5.0 g, agar 20 g, distilled water 1000 ml

Trypticase soy agar: Trypticase (animal peptone) 15 g, phytone (soy peptone) 5.0 g, NaCl 5.0 g, agar 20 g, distilled water 1000 ml, pH 7.3

Tryptone broth agar: Tryptone 10.0 g, NaCl 5.0 g, CaCl₂* 1.0 g, agar 20 g, distilled water 1000 ml *Sterilized separately and mixed with medium just before pouring

Simmons citrate agar: Ammonium dihydrogen phosphate 1.0 g, dipotassium hydrogen phosphate 1.0, NaCl 5.0 g, sodium citrate 2.0 g, magnesium sulphate 0.2 g, bromothymol blue 0.08 g, agar 20 g, distilled water 1000 ml, pH 6.9

SIM (Sulphide, Indole, Motility) medium: Peptone 30.0 g, Beef extract 3.0 g, Ferrous ammonium sulfate 0.2 g, Sodium thiosulfate 0.025 g, Agar 3.0 g, D/W 1000 ml, pH 7.3.

Yeast Extract Mannitol Agar: K₂HPO₄ 0.5 g, K₂SO₄·7H₂O 0.2 g, NaCl 0.1g, Mannitol 10.0 g, Yeast extract 1.0 g, Agar 20.0 g, Congo red* (1 % solution) 2.5 ml, Distilled water 1000 ml

*Congo red solution is to be sterilized separately and added to the medium at a time of pouring in plates.

Ashby's Agar medium: Mannitol 20.0 g, K₂HPO₄ 0.2 g, MgSO₄·7H₂O 0.2 g, NaCl 0.2 g, K₂SO₄ 0.1 g, CaCO₃ 5.0 g, Agar 15.0 g, D/W 1000 ml

Pikovskaya's agar medium: Yeast extract 0.5 g, Dextrose 10.0 g, Calcium phosphate 5.0 g, Ammonium sulphate 0.5 g,

Potassium chloride 0.2 g, Magnesium sulphate 0.10g, Manganese sulphate 0.0001 g, Ferrous sulphate 0.0001 g, 0.5% of Bromophenol blue dye, D/W 1000 ml, pH 7.0

FUNGAL GROWTH

Starch agar (pH 7.0): Starch soluble 20.0 g, peptone 5.0 g, beef extract 3.0 g, agar 20 g, distilled water 1000 ml

Sabouraud's dextrose agar (pH 5.6): Peptone 10.0 g, dextrose 40.0 g, agar 20 g, distilled water 1000 ml

Potato dextrose agar (pH 7.3): Potato (peeled, cut) 200.0 g, dextrose 20.0gm, agar 20 g, distilled water 1000 ml# Boil peeled, cut potatoes (200 g) in 500 ml water for 10 minutes, filter extract through muslin cloth, add dextrose and agar to filtrate, and make up the volume to 1000 ml

Carboxymethyl cellulose (CMC) agar media: KH_2PO_4 2.0 g, $(\text{NH}_4)_2\text{SO}_4$ 1.4 g, $\text{MgSO}_4 \cdot 7\text{H}_2\text{O}$ 0.3 g, CaCl_2 0.3 g, yeast extract 0.4 g; $\text{FeSO}_4 \cdot 7\text{H}_2\text{O}$ 0.005 g; MnSO_4 0.0016 g; ZnCl_2 0.0017 g, CoCl_2 0.002 g, CMC-Na 5.0 g, agar 15.0 g, D/W 1000ml pH 5.0.

ACTINOMYCETES GROWTH

International Streptomyces Protocol medium-2 (ISP-2): dextrose 4.0 g, yeast extract 4.0 g, malt extract 10.0 g, agar 20.0 g, distilled water 1000ml

Czapek-Dox (modified) agar (pH 6.4–7.0): Sodium nitrate 2.0 g, KCl 0.5 g, magnesium sulfate 0.5, dipotassium hydrogen phosphate 1.0, ferrous sulfate 0.01 g, starch 10.0gm, peptone 10 g, agar 20 g, distilled water 1000 ml.

MORPHOLOGY FUNGAL CULTURE CHARACTERISTICS.

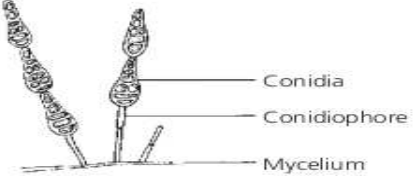
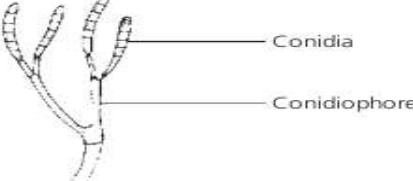
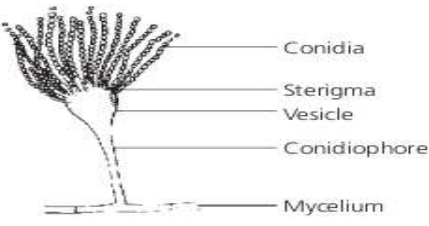
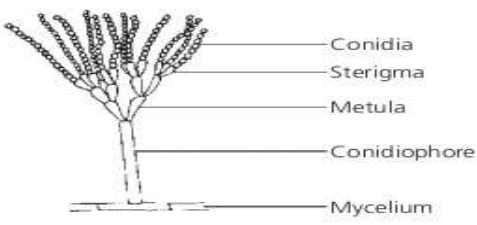
DIAGRAM	COLONIAL MORPHOLOGY	MICROSCOPIC APPEARANCE
<p>Molds (continued)</p>  <p><i>Alternaria:</i> Normally found on plant material; also found in house dust</p>	<p>Grayish-green or black colonies with gray edges rapidly swarming over entire plate; aerial mycelium not very dense, appears grayish to white</p>	<p>Multicelled spores (conidia) are pear-shaped and attached to single conidiophores arising from a septate mycelium</p>
 <p><i>Fusarium:</i> Found in soil; also likely in eye infections</p>	<p>Woolly, white, fuzzy colonies changing color to pink, purple, or yellow</p>	<p>Spores (conidia) are oval or crescent-shaped and attached to conidiophores arising from a septate mycelium; some spores are single cells, some are multicelled</p>
 <p><i>Aspergillus:</i> Plant and animal pathogens; some species used industrially</p>	<p>White colonies become greenish-blue, black, or brown as culture matures</p>	<p>Single-celled spores (conidia) in chains developing at the end of the sterigma arising from the terminal bulb of the conidiophore, the vesicle; long conidiophores arise from a septate mycelium</p>
 <p><i>Penicillium:</i> Antibiotic-producing citrus fruit contaminant; soil inhabitant</p>	<p>Mature cultures usually greenish or blue-green</p>	<p>Single-celled spores (conidia) in chains develop at the end of the sterigma arising from the metula of the conidiophore; branching conidiophores arise from a septate mycelium</p>

DIAGRAM

COLONIAL MORPHOLOGY

MICROSCOPIC APPEARANCE

Molds

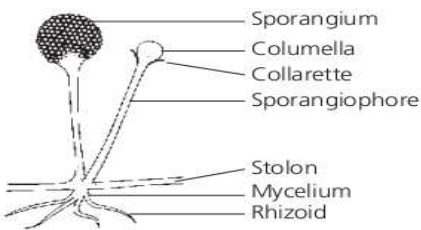

Rhizopus:
Black bread mold; common laboratory contaminant

Rapidly growing white-colored fungus swarms over entire plate; aerial mycelium cottony and fuzzy

Spores are oval, colorless, or brown; nonseptate mycelium gives rise to straight sporangiophores that terminate with black sporangium containing a columella; rootlike hyphae (rhizoids) penetrate the medium

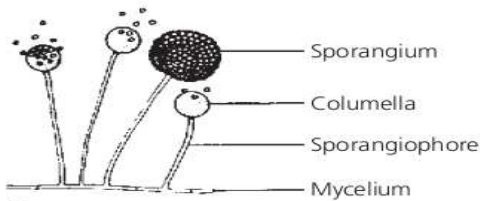

Mucor:
Food contaminant

Resembles the colonies of *Rhizopus* except that it lacks rhizoids and collarettes. Sporangiphore arises directly from mycelial mat. Note: Branching sporangiophores may occur with *Mucor*.

Spores are oval; nonseptate mycelium gives rise to single sporangiophores with globular sporangium containing a columella; there are no rhizoids

Molds (continued)

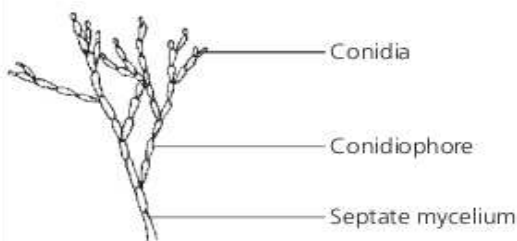

Cladosporium:
Dead and decaying plants

Small, heaped colonies are greenish-black and powdery

Spores (conidia) develop at the end of complex conidiophores arising from a septate mycelium that is usually brownish

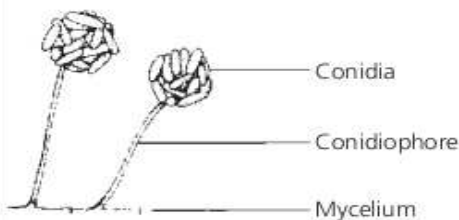

Cephalosporium:
Antibiotic production

Rapidly growing compact and moist colonies becoming cottony with aerial hyphae that are gray or rose-colored

Single-celled conical or elliptical spores (conidia) held together in clusters at the tips of the conidiophores by a mucoid substance; erect, unbranched conidiophores arise from a septate mycelium

Yeast

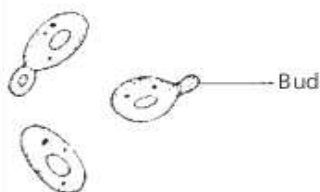

Torula:
Cheese and food contaminant

Colonies are pink, moist, with unbroken, even edges

Cells are oval, colorless, and reproduce by budding

Molds (continued)

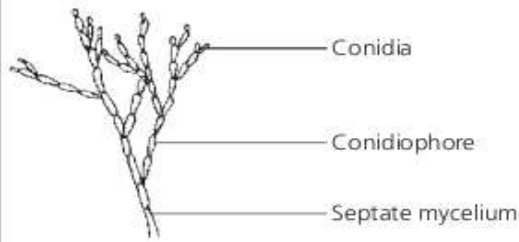

Small, heaped colonies are greenish-black and powdery

Spores (conidia) develop at the end of complex conidiophores arising from a septate mycelium that is usually brownish

Cladosporium:
Dead and decaying plants

ILLUSTRATIONS OF FRUITING BODIES OF SOME FUNGI ISOLATED FROM SOIL

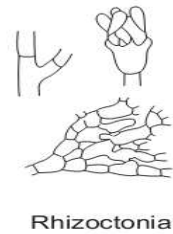
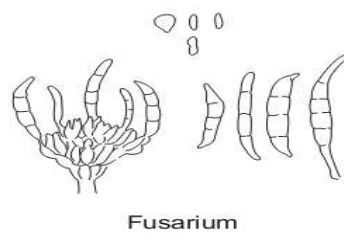
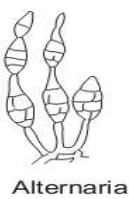
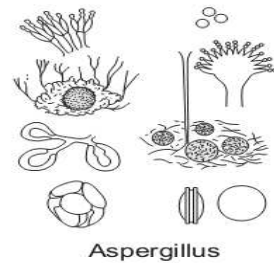
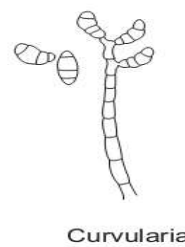
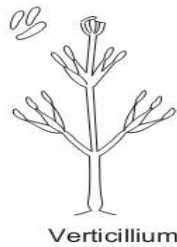
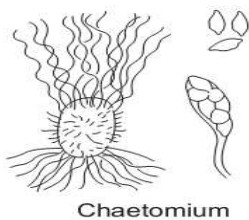
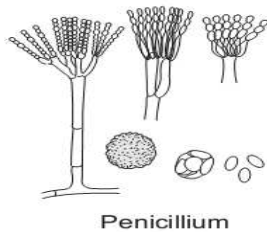
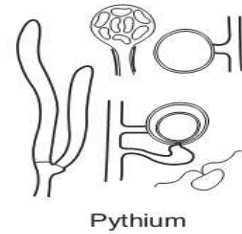
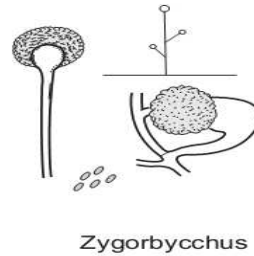
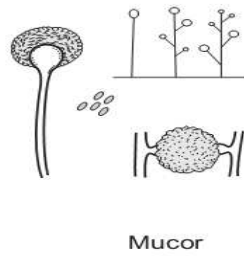
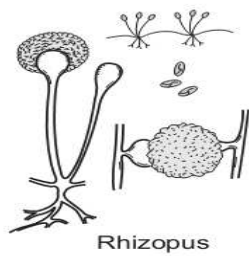

Major examples of Gram positive and Gram-Negative bacterial forms:

